

Belangrijk

Rail en de PRS behuizing siliconiseren als aangegeven.

Important

Lubricate rail and faces of PRS-housing as shown with silicone spray.

Wichtig

Schiene und PRS-Gehäuse silikonisieren wie angegeben.

Importants

Lubrifier le rail et les faces internes du PRS comme indiqué.

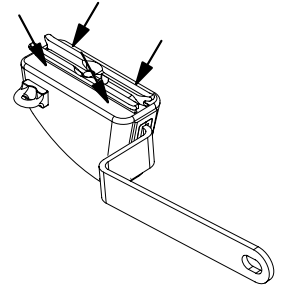
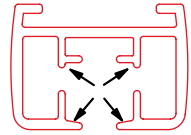

- > Altijd alle ophang punten gebruiken (zie afb.)
- > Haak/plooiafstand: minimaal 10 cm.
- > Use all carrier eyes for correct functioning (as shown)
- > Ensure hook/fold centres of 10 cm minimal.
- > Immer alle Augen der Vorläufer gebrauchen (siehe Abb.)
- > Haken/Falten Abstand minimal 10 cm.
- > Tous les trous doivent toujours être utilisés (voir la figure)
- > Distance minimale des agrafes 10 cm.

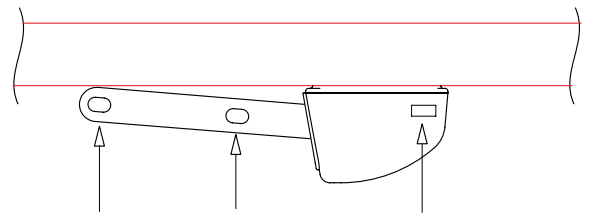

- | | | |
|-----------------------|--------------------------|--------------------------|
| 1 ^e haak | 2 ^e haak | 3 ^e haak |
| 1 st hook | 2 nd hook | 3 rd hook |
| 1 ^{er} Haken | 2 ^{er} Haken | 3 ^{er} Haken |
| 1er agrafe | 2 ^{ième} agrafe | 3 ^{ième} agrafe |

Beugel plaatsen / Place carrier
Träger einführen / Montage de la patte

Oogje plaatsen / Insert eye
Auge einstecken / Fixation de l'accroche

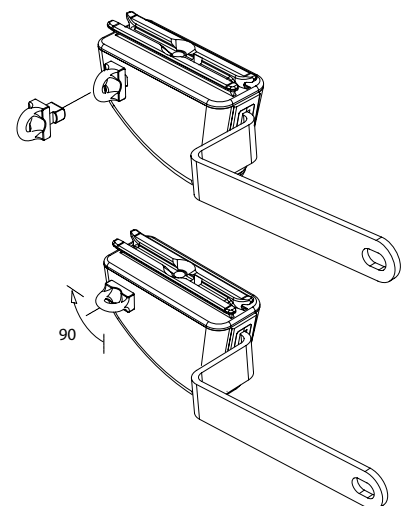
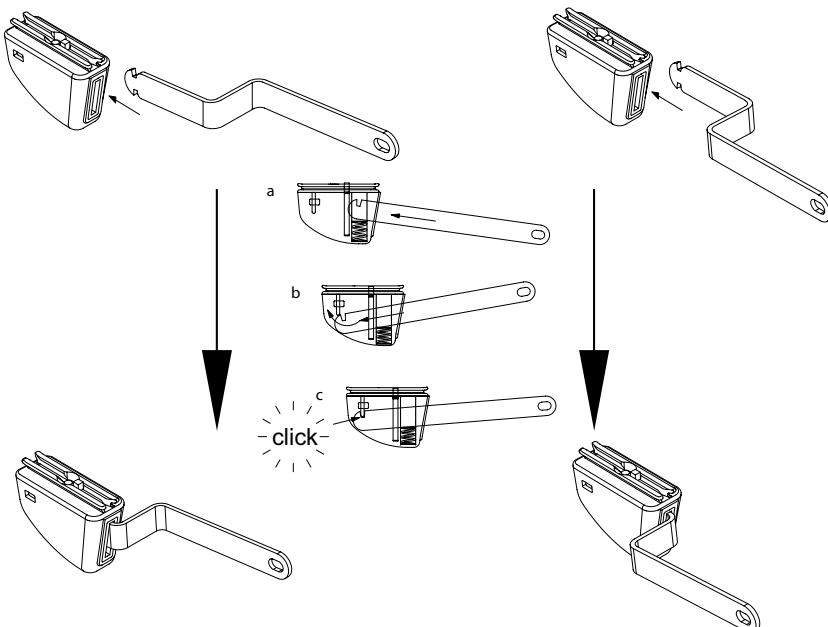

Werking / Functioning / Funktionsablauf / En fonction

ontkoppelen / disconnect / Entkoppelling / déconnecté:

6200
6300
6302

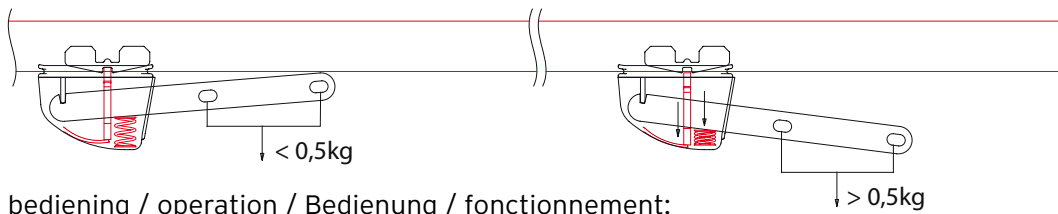
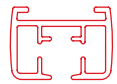

bediening / operation / Bedienung / fonctionnement:

met de hand / manually / mit der Hand / manuel

electrisch / electrically / elektrisch / électrique

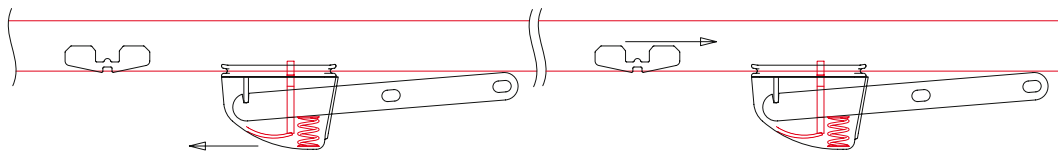

aankoppelen / reconnect / Koppelung / Connection:

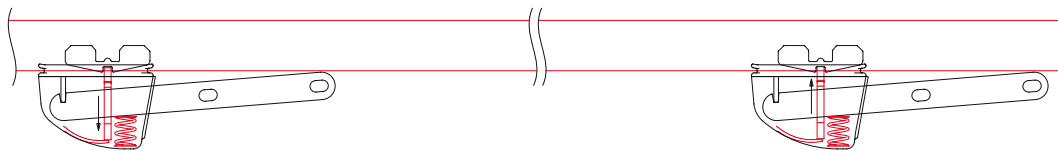

Onderdelen / Component / Zubehör / Composants

6284-PRS-1000

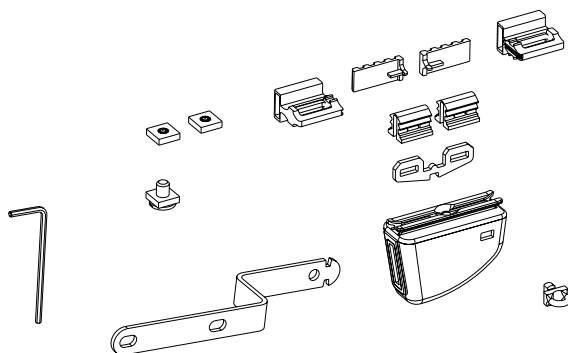

6285-PRS-2000

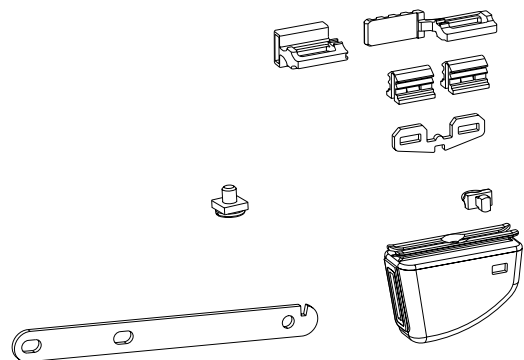

6009

speciale glijder / glider / Gleiter / glisseur

